

Shhh...We're in the box!

MYO acoustic booths

High quality acoustics, made in France

Each of our acoustic cabins is manufactured with particular care in our workshops in the Hauts-de-France region. Custom-built or ready-to-install, they can be adapted to your needs, and can be assembled, dismantled and moved at will. Guaranteeing a serene working environment, they evolve with your spaces, adjusting to each environment for optimum comfort.



Ready-to-install
A booth that can be quickly delivered, installed and ready to use



Ready-to-create
Made-to-measure and fully customizable

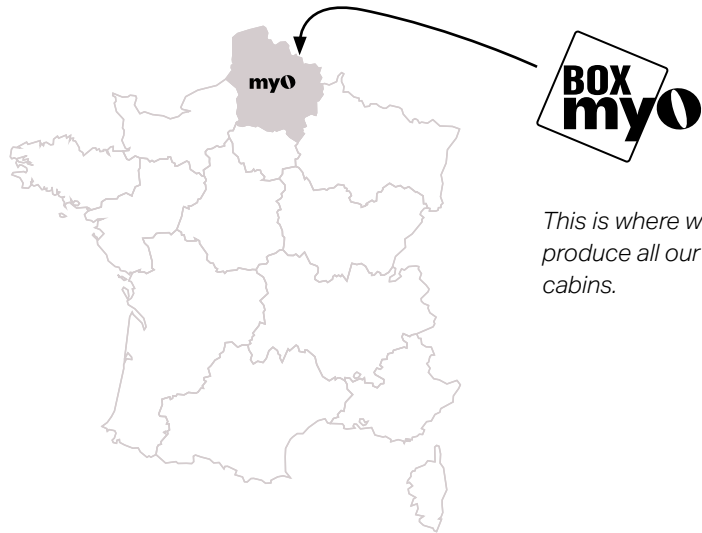

This is where we produce all our acoustic cabins.



100% eco-friendly

All the materials that go into our acoustic booths have been selected on the basis of their environmental labels.

Our booths are designed and manufactured at our workshops in the North of France, and are part of our policy to use short supply chains: the majority of our suppliers are located less than 100 km far from our company.

100% comfortable

Our booths are known for their acoustic qualities and are all tested in line with the ISO 140-4 standard. They guarantee optimal isolation from outside noise so you can work, telephone and confidentially talk, all in a space where every detail has been designed for your everyday comfort and efficiency.



The READY-TO-INSTALL acoustic booth



The Woody box is absolutely perfect for making a confidential phone call, rehearsing a presentation in peace or conducting a videoconference with an out-of-office team. It's easy to install, can be placed wherever it is needed, assembled and disassembled as many times as you want...



Designed & produced in our workshops

FRENCH MANUFACTURING
SUSTAINABLE MATERIALS

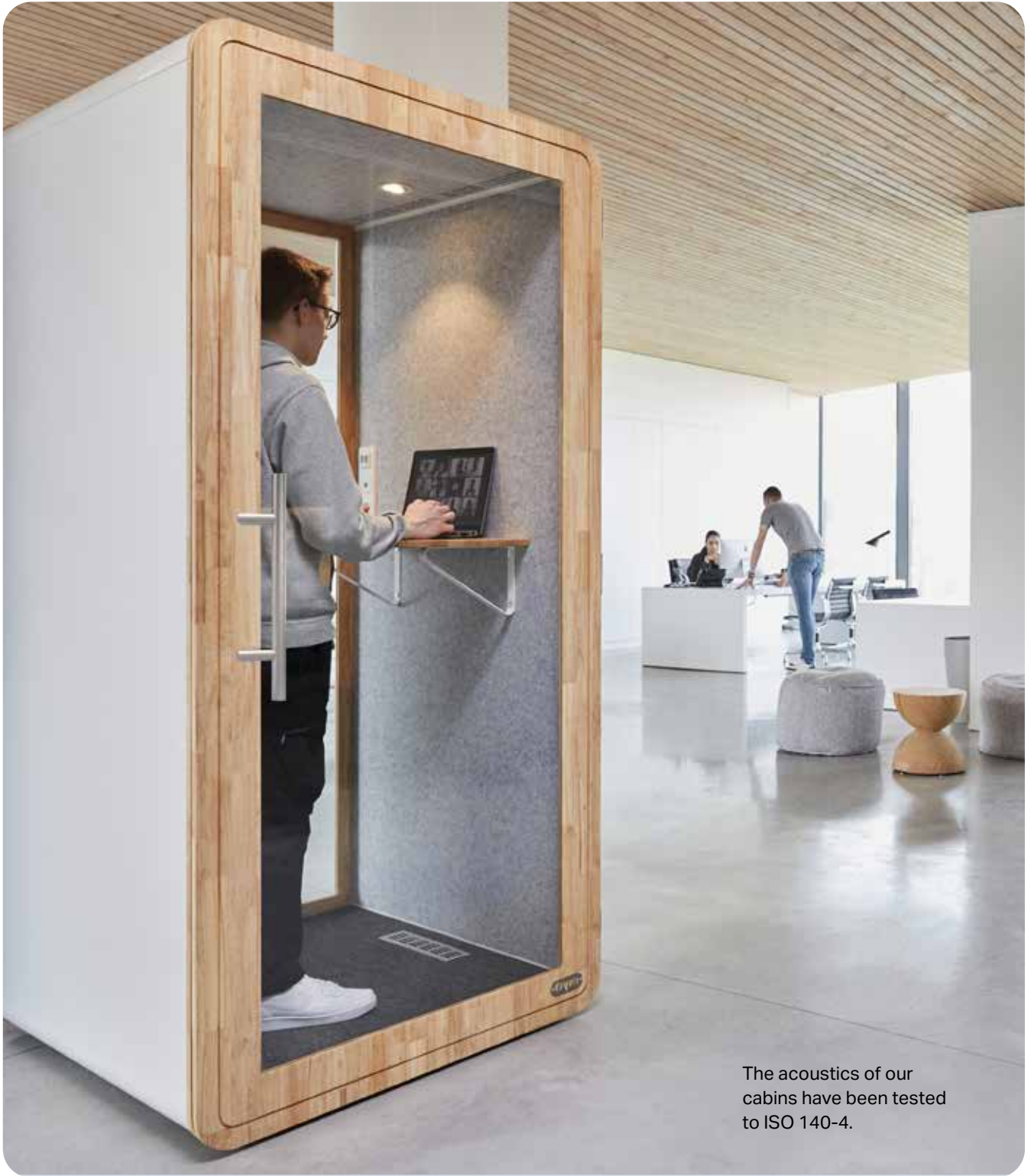

The acoustics of our cabins have been tested to ISO 140-4.



28 dB indoor noise reduction from outside.



The sound produced inside is barely perceptible from the outside, thanks to a 37 dB reduction.

Designed for comfort

ACOUSTIC | CONNECTED | VENTILATED



 Equipped & connected to make both phone and video calls.



| 42 m³/h*

Quiet ventilation: 2 complete air exchange cycles every 5 minutes.

* DON'T BE FOOLED!
the ventilation manufacturer's data = 174 m³/h
Here we give you the airflow actually measured in situ.



Up & running in less than 45 minutes!

READY TO INSTALL
QUICK ASSEMBLY AND DISASSEMBLY
PLUG & PLAY

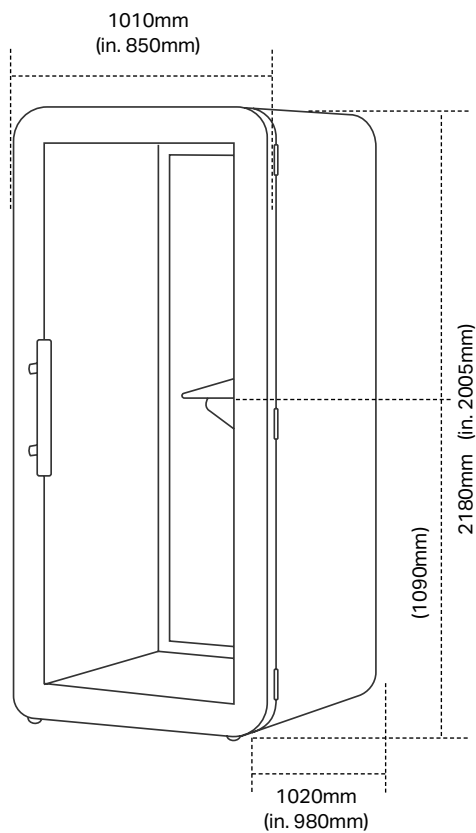

- Coordinated exterior/interior colors: black - white
- Choice of door opening direction :

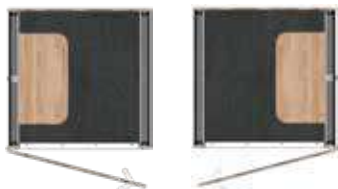

Because floors are NEVER straight: flatness adjustment with integrated cylinders!



OPTIONS



Privacy screen magnetic
Removable, perforated acoustic panel on rear panel [dim. 1010 x 2160mm]



Color interior trim
Hush fabric trim (Gabriel®) on acoustic panel [28 colors to choose from].



The READY-TO-CREATE acoustic booth



MOOD BOX [1]



MOOD BOX [2]

Mood box acoustic booths can be configured from A to Z, with a multitude of possibilities. Depending on your needs, your space: 1, 2, 4 ... 8 people, there's a Mood box for everyone!

Designed & produced in our workshops

FRENCH MANUFACTURING
SUSTAINABLE MATERIALS



MOOD BOX [+]



Mood box [1]

The ready-to-create acoustic booth



1 PERSONNE



29 dB indoor noise reduction from outside.

The sound produced inside is barely perceptible from the outside, thanks to a 36 dB reduction.



The acoustics of our cabins have been tested to ISO 140-4.

A small box with great comfort!

ACOUSTIC | CONNECTED | VENTILATED



Equipped & connected to make both phone and video calls.

Solo or against each other.



142 m³/h*

Quiet ventilation: 2 complete air exchange cycles every 5 minutes.

* DON'T BE FOOLED:
the ventilation manufacturer's data = 174 m³/h
Here we give you the airflow actually measured in situ.



A box that moves with your needs

FREESTANDING & MOVEABLE

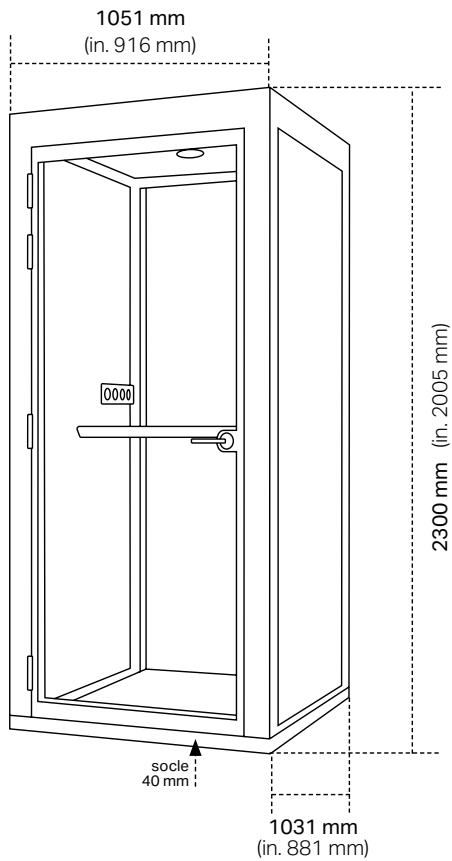

- Single electrical connection: from floor or ceiling



Moveable
Wooden base and wheel kit

OPTIONS

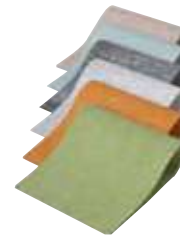

Interior customization
Hush fabric covering (Gabriel®) on acoustic panel [28 colors to choose from].



External customization

- Etiher melamine or sheet-metal finish
- Magnetic writing board: integrated into the frame (back or side of the box)

- Angled or parallel glass configuration
- Choice of door opening direction





Mood box [2]

The ready-to-create acoustic booth



2 PEOPLE



The acoustics of our cabins have been tested to ISO 140-4.



29 dB indoor noise reduction from outside.



The sound produced inside is barely perceptible from the outside, thanks to a 36 dB reduction.

A box equipped for 2

ACOUSTIC | CONNECTED | VENTILATED



Equipped & connected to make both phone and video calls.



| 83 m³/h*

Quiet ventilation: 2 complete air exchange cycles every 5 minutes.

* DON'T BE FOOLED!
the ventilation manufacturer's data = 348 m³/h
Here we give you the airflow actually measured in situ.



1 or 2-door configuration

FREESTANDING & MOVEABLE

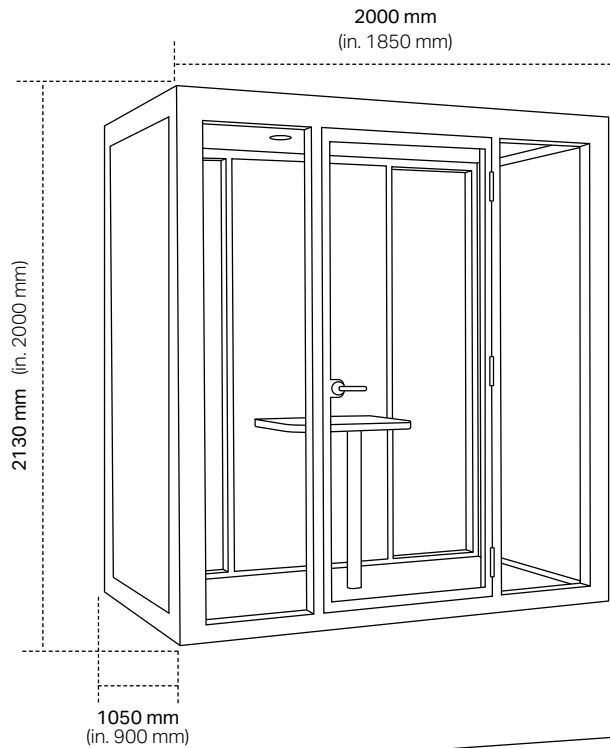

1-door configuration :

- Choice of door opening direction
- Table = 550 x 600mm

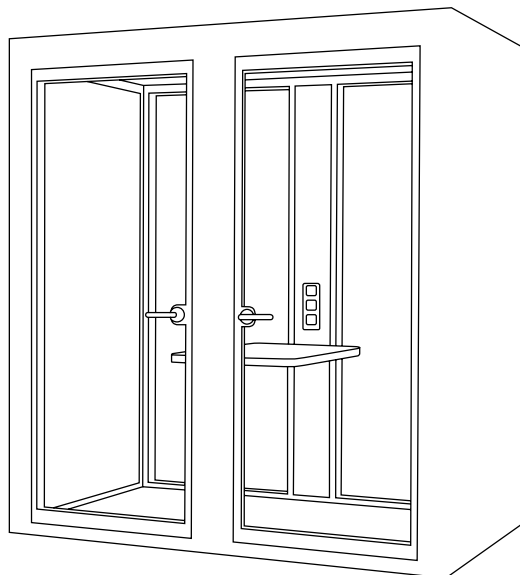

2-door configuration :

- Table = 900x600mm



Moveable
Wooden base and wheel kit

OPTIONS

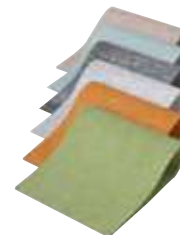

Interior customization
Hush fabric covering (Gabriel®) on acoustic panel [28 colors to choose from].



Exterior customization

Melamine or sheet metal cladding

Single electrical connection: from floor or ceiling



Mood box [+]

The ready-to-create acoustic booth



1 TO 8 PEOPLE

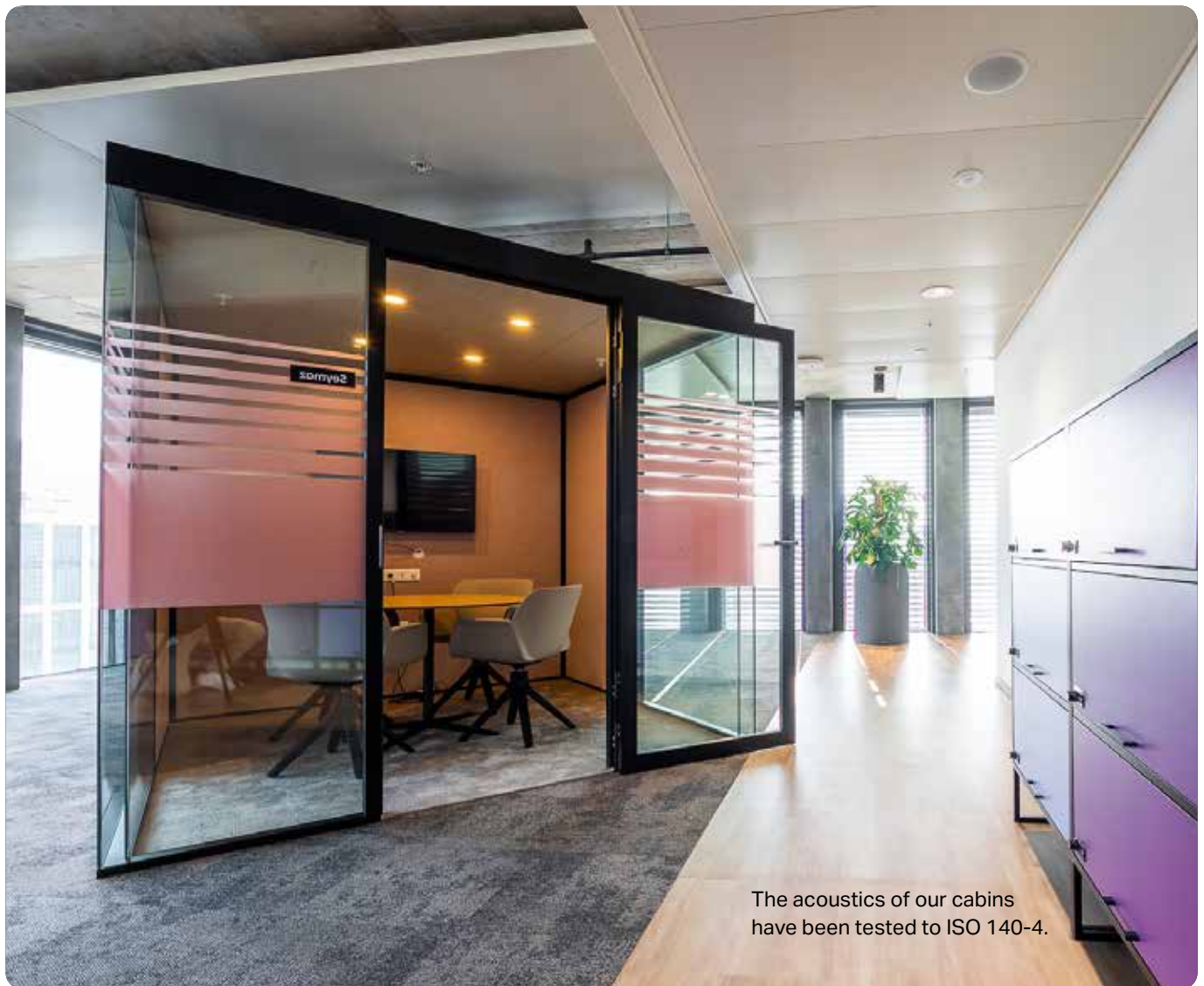

The acoustics of our cabins have been tested to ISO 140-4.



33 dB indoor noise reduction from outside.



The sound produced inside is barely perceptible from the outside, thanks to a 42 dB reduction.

The box for all meetings

ACOUSTIC | CONNECTED | VENTILATED



Equipped & connected
to make both phone and
video calls.

Solo or against each other.



179 à 240 m³/h*

Quiet ventilation: 1 complete air exchange cycles
every 5 minutes.

* DON'T BE FOOLED!
the ventilation manufacturer's data = 348 to 1044 m³/h
Here we give you the airflow actually measured in situ.



1 or 2-door configuration

FREESTANDING & MOVEABLE

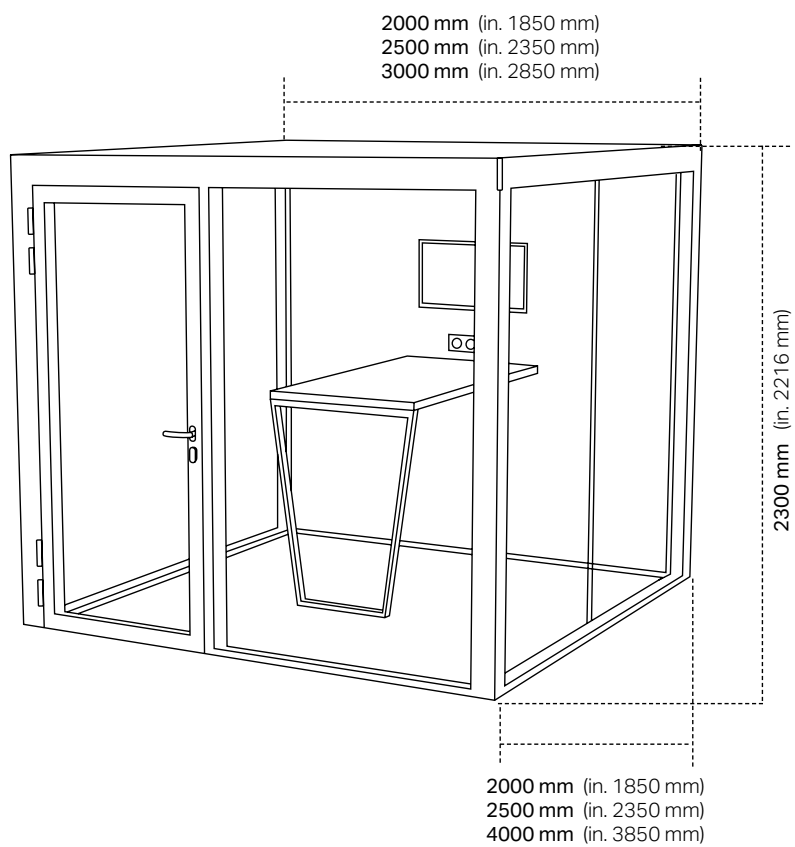

Single electrical connection:
under the floor, either through the
ceiling or at the rear of the box.



Table
Height 1100mm,
Thickness 40mm
Dim. 500 x 1200mm
or 800 x 1500mm
White melamine with
wood-veneered edges
High-gloss lacquered
steel base

OPTIONS



Screen connection:
HDMI + RJ45



Interior customization
Hush fabric covering
(Gabriel®) on acoustic
panel [28 colors to
choose from].



Exterior personalization

- Magnetic writing panel on a solid infill either inside or outside
- Melamine or sheet metal finish



The READY-TO-CREATE acoustic booth

Your acoustic booth in 4 steps

To make your acoustic booth unique, we make it according to your exact requirements, to match the aesthetics of your space and even the colours of your company...

You can freely choose the configuration, inside layout and finishes, we will deal with all the technical aspects.

1. Your booth size

1 PERSON



Mood **box**[1]
W. 1051 x D. 1031mm
H. 2300mm
i.e. 1m²

2 PEOPLE

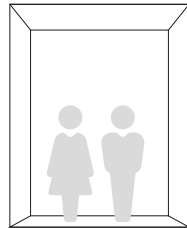

Mood **box**[2]
W. 2000 x D. 1050mm
H. 2130mm
i.e. 2m²

4 PEOPLE

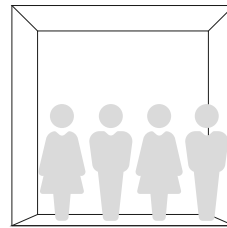

Mood **box**[+]
W. 2000 x D. 2000mm
W. 2500 x D. 2500mm
H. 2300mm
i.e. 4 to 6m²

8 PEOPLE

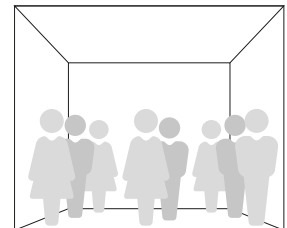

Mood **box**[+]
W. 3000mm x D. 4000mm
H. 2300mm
i.e. 12m²

A booth to your exact measurements ?

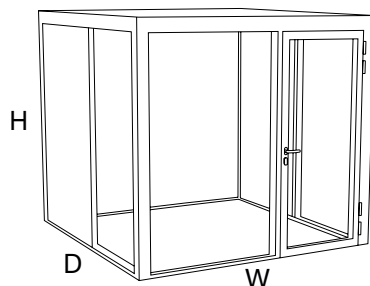

The floor space can be dimensioned to the following measurements:

W. 1000mm à 3600mm
D. 1000mm à 6000mm
H. 2300mm

2. Configure your space

Mood box[1]



Configuration 1

- 2 perpendicular solid sides
- glass side on the right or left
- door opens out on the solid side



Configuration 2

- 2 parallel solid sides
- glass side opposite the door

Mood box[2]



Configuration 1

- 3 solid sides
- 2 doors



Configuration 2

- 2 solid sides
- 1 glass side
- 2 doors



Configuration 3

- 3 solid sides
- 1 door



Configuration 4

- 2 solid sides
- 1 solid/glass side
- 1 door

Mood box[+]



Configuration 1

- 1 solid side
- 3 glass sides
- 1 door



Configuration 2

- 2 solid sides
- 2 glass sides
- 1 door



Configuration 3

- 1 solid side
- 2 solid/glass sides
- 1 glass side
- 1 door



Configuration 4

- 1 solid side
- 3 glass sides
- 1 door



Configuration 5

- 1 solid side
- 2 solid/glass sides
- 1 glass side
- 1 door

3. Customize the finish

Door trim Color coordinated with frame: black / stainless steel

Lock with or without European barrel

Structure Aluminium

9010 BRI

9005 FTC

7016 FTC

RAL spécifique

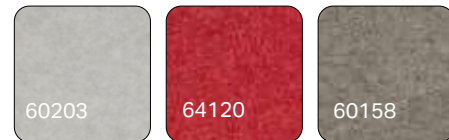
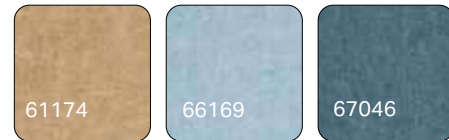
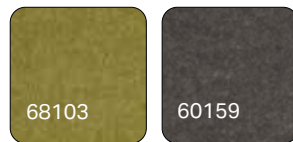

HUSH - stock colours (other colours available)

Optional finish: Gabriel® HUSH fabrics



Interior wall/ceiling filling PET mottled grey (light or dark)

External infill
Melamine panel
Sheet metal panel
Glazing

non-contractual colours

4. Equip your Mood box

The Mood box provides workspaces of varying sizes, that can be fitted out according to your needs: as a meeting room, office, relaxation space, etc.



Mood box[2] dimensions

W. 2000mm
D. 1050 mm
H. 2300mm



Mood box[+] dimensions

W. 2000 / 2500mm
D. 2000 / 2500mm
H. 2300mm



Mood box[+] dimensions

W. 3000mm
D. 4000mm
H. 2300mm

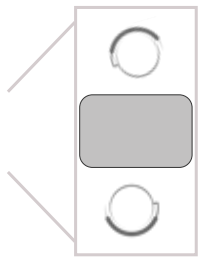

Table 900 x 600mm

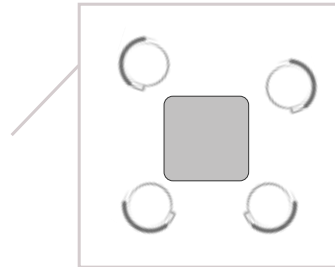

Table 700 x 700mm

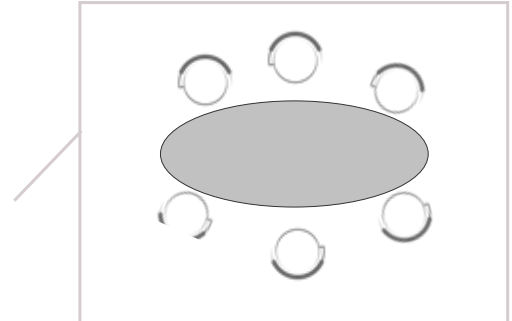

Table 1000 x 2500mm

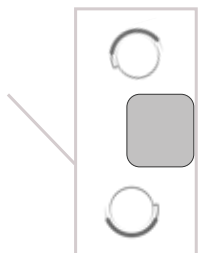

Table 550 x 600mm

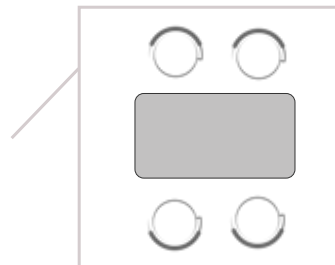

Table 800 x 1500mm

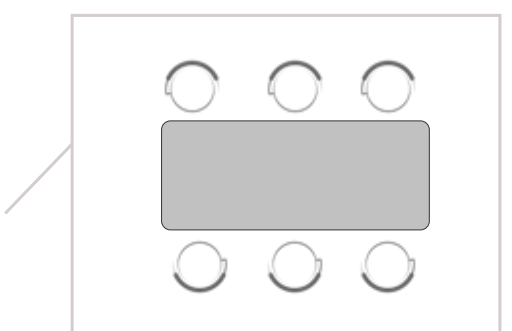

Table 1000 x 2500mm

FURNITURE DIMENSIONS ARE GIVEN FOR INFORMATION ONLY



Spaces to be
together.

Acoustic solutions for workspaces

MYO designs and distributes soundproofing solutions for open business areas: booths, panels, suspension and column lighting, office partitions, art panels, etc.

Naturally eco-friendly

Our materials are selected for their environmental qualities: PEFC panels, EU ECOLABEL fabrics, OEKO-TEX acoustic foam...

High-quality soundproofing

All our solutions are tested in independent testing laboratories in line with the ISO 140-4 standard.

Made in France

All the MYO products are manufactured in the North of France according to our short supply chain policy.



ref MYO_BOX_0924

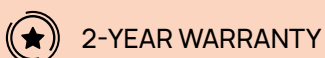

myo-solutions.com